

## FONTANA ROSE GOLD BRASS COMMERCIAL AUTOMATIC MOTION SENSOR FAUCET SPECS

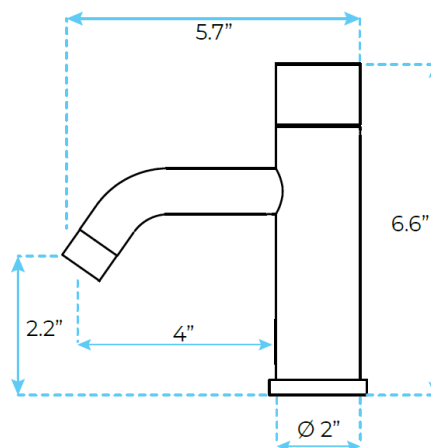

### SPECS:

- Power supply options: For cold or premixed water (mixer sold separately)
- AC - transformer with a plug to electricity and/or DC - battery pack for 4 x AA alkaline batteries (batteries not included) - on average lasts for 108,000 use cycles 10 seconds metering cycles
- Sensing distance by default: 4" (10cm)
- Sensing range: 4"-12" (10cm - 31cm) adjustable with a screwdriver on backside of the sensor
- Water pressure: 15-90 PSI, recommended 43.5 PSI
- Water temperature: 34-120° Fahrenheit (1-50° Celsius)
- Installation: Deck-Mount 1-hole, Touch-free
- Material: Solid Brass Construction

